

Anti-Cash Trapping Solution

Prevent Cash Trapping and Transaction Reversal Fraud at the ATM. Secure your self-service fleet with Diebold Nixdorf's innovative Anti-Cash Trapping Solution (ACTS).

Thanks to built-in sensors ACTS can detect cash traps in advance of transactions and secure the cash if a cash trap is detected during a transaction. Additionally, it can detect shutter drillings related to Transaction Reversal Fraud attacks. Thanks to DN Series modular design this solution is compatible with all DN Series models (*except DN 100D and DN 150D for which we offer a different solution) and can be upgraded on-site. Depending on the procedure you define, the device can execute an emergency retract on its own, wait for further orders from the application or the host level, and/or switch into an "out of service" mode immediately.



More Personalized

ACTS offers several operation modes that you can adapt to fit your requirements: From only sending a report to taking the ATM out of operation automatically.



More Integrated

This solution is compatible with all DN Series ATMs that have a cash cover. The decision logic is integrated with ProBase/C.



More Available

You can choose to only block cash transactions temporarily without taking the device out of service entirely until someone can come to check. Non-cash transactions can then still be performed.



More Efficient

Both the size and power consumption have been optimized in this solution while the complexity of the module has been reduced.



More Future-Ready

ACTS can be equipped on-site on existing DN Series ATMs thanks to its focus on modularity.



More Secure

An integrated mesh/drill protection grid in the shutter blade provides additional security.

Features

SPECIFICATIONS

- Build-in compatible with existing Cash Cove
- Direct connect via Dispensing/Recycling Unit
- Optimized cash dispensing logic
- Operation with XFS Service Provider Interface Standard (ProBase V1.4) Cash unit using Trusted Device communication
- Optimized integration for operation also with ActivEdge Card reader
- Operation modes could be set by parameter

Supported Operation modes:

(Precondition of the ACTS sensors and dispensing logic, evaluate a possible attack situation and report alarm event)

- **Report only** Alarm events, on-site application or host decide further alarm procedure
- **Block Transaction only:** reject current cash-out or Cash in transaction
- Set ATM **“out of service”**, can be put back via operation request access **T/SOP** with profile and right to reset ACTS alternate operator with access to **SOP** to reset ACTS
- **Automatic Operation:** ACTS report alarm event to higher application layers, but decide by his own automatically to set system “Out of Service” as well bring system “back to operation”, if cash trap situation is not longer detected.

Full Application Software support with:

- Agilis 3 91x SP5
- VCP-Lite (ProCash)
 - ProCash/xDC V3.1/31
 - ProCash/xDC V4.0.0
- VCP-Pro (ProFlex4)
 - ProFlex4 V4.3.1

Other applications need additional enhancements/customization to operate ACTS

SECURITY

- Detects foreign objects placed in front of the Cash Cove for a set period of time
- Detects drill attacks to the Cash Cove in advance of Cash Trap and/or a TRF [Transaction Reversal Fraud] attack
- Sensors hidden in Cash Gove Shutter Design

RELIABILITY

- Engineered to process millions of Transactions (assembly variant of existing cash cove)
- Paired with DN AllConnect Data Engine

SYSTEM AVAILABILITY

- All DN Series ATMs except DN Series 100D and 150D
- Minimum Precondition to operate/upgrade DN Series system ProBase/C V1.4/xx

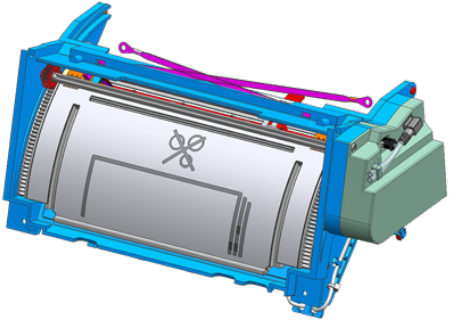

System Availability



To learn more, visit DieboldNixdorf.com.